

eW Profile Powercore

100 / 220 – 240 VAC

POWERCORE®
CK TECHNOLOGY

D I M A N D®
CK TECHNOLOGY



Installation Instructions

Instructions d'installation
Installationsanweisungen
Instrucciones de instalación
Istruzioni per l'installazione
Installatie-instructies
インストール手順
安裝指示

Fixtures must be installed by a qualified electrician in accordance with all national and local electrical and construction codes and regulation.

Les appareils d'éclairage doivent être installés par un électricien diplômé conformément à tous les codes et réglementations électriques et de construction nationaux et locaux.

Die Beleuchtungskörper sind von einem qualifizierten Elektriker in Übereinstimmung mit allen geltenden Vorschriften zu installieren.

Las lámparas deben ser instaladas por un electricista calificado y cumpliendo todas las normas y regulaciones, tanto nacionales como locales, sobre instalaciones eléctricas y obras.

I gruppi di illuminazione devono essere installati da un elettricista qualificato in conformità con le norme locali e nazionali vigenti in materia di costruzioni edilizie e installazione di impianti elettrici.

Armaturen moeten worden aangebracht door een gekwalificeerde elektricien en in overeenstemming met alle nationale en plaatselijke elektriciteits- en bouwvoorschriften.

フィクスチャの設置は、資格を持つ電気技術者が行ってください。その際、国および地域の電気、建築関連の法令および規則をすべて遵守してください。

必须由合乎所有国家和当地电器与建筑法规及规定的合格电工安装灯具

www.colorkinetics.com/support

1

Make sure power is OFF Assurez-vous que l'alimentation est coupée Vergewissern Sie sich, dass die Stromzufuhr **ABGESCHALTET** ist
Asegúrese de que la alimentación eléctrica esté desconectada Assicurarsi che l'alimentazione sia disattivata Zorg dat de voeding is uitgeschakeld
電源が OFFであることを確認します 确保电源关闭

2

Mount the first fixture Montez le premier appareil d'éclairage Befestigen Sie den ersten Beleuchtungskörper Monte la primera lámpara
Montare il primo gruppo di illuminazione Monteer de eerste armatuur 最初のフィクスチャを取り付けます 安裝第一个灯具

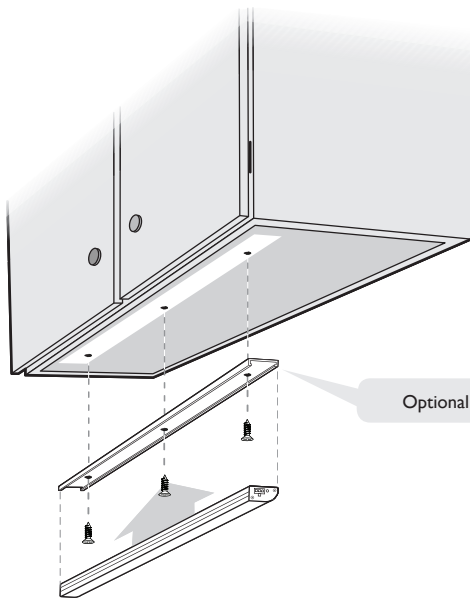

Optional Mounting Track

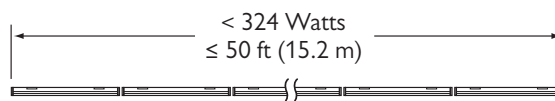
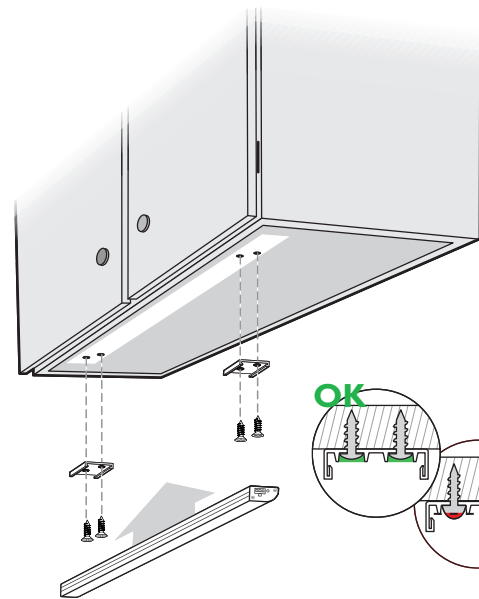

Fixture Length	Watts
9.25 in (235 mm)	6 W
19.25 in (489 mm)	13 W
39.25 in (997 mm)	25 W

3

Connect additional fixtures

Branchez les appareils d'éclairage supplémentaires
 Schließen Sie weitere Beleuchtungskörper an
 Conecte las lámparas adicionales
 Collegare gli altri gruppi di illuminazione
 Sluit extra armaturen aan
 他のフィクスチャを接続します
 连接其它灯具

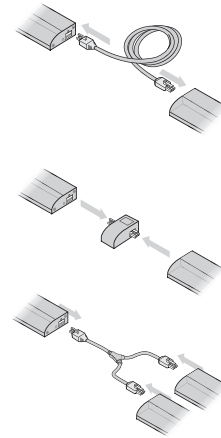
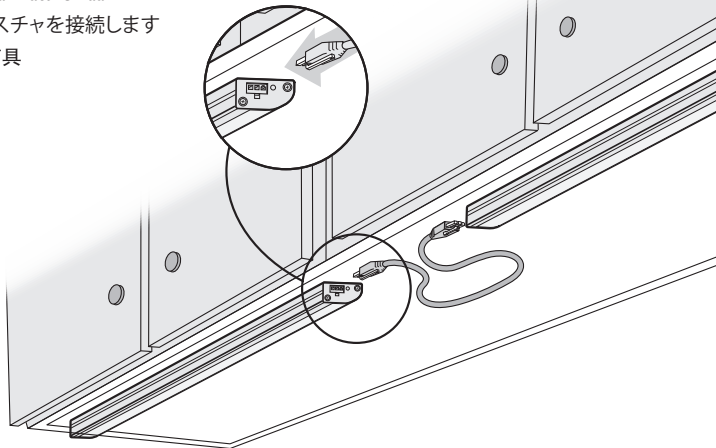

Jumper Cables
 6 in (152 mm)
 —
 12 in (305 mm)
 —
 18 in (457 mm)
 —
 5 ft (1.5 m)

End-to-End Connector
 .875 in (22 mm)

"Y" Jumper Cable
 16.5 in (419 mm)

4

Attach Terminator

Fixez le terminateur
 Attach Terminator
 Adjuntar terminación
 Fissare il terminatore
 Terminator bevestigen
 ターミネータ取り付け
 连接端接器

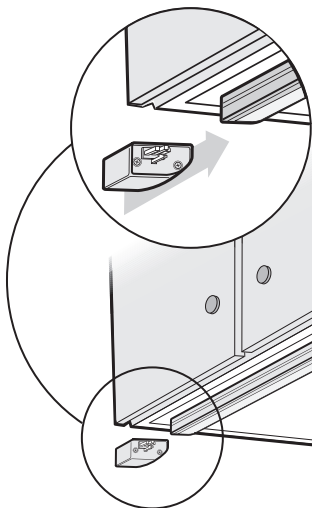

5

Connect the leader cable

Branchez le câble principal Schließen Sie das Masterkabel an
 Enchufe el cable de alimentación eléctrica principal Collegare il cavo pilota
 Sluit de geleidekabel aan リーダーケーブルを接続します 连接引线电缆

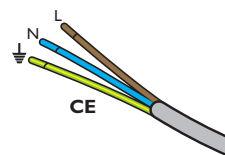

(L)

Line Voltage
 Tension de secteur
 Netzspannung
 Tensión de línea
 Tensione di linea
 Netspanning
 線間電圧
 线路电压

(N)

Neutral
 Neutral
 Neutro
 Neutro
 Neutraal
 中性線
 零线

(⏚)

Ground
 Terre
 Masse
 Toma de tierra
 Terra
 Aarde
 アース
 接地

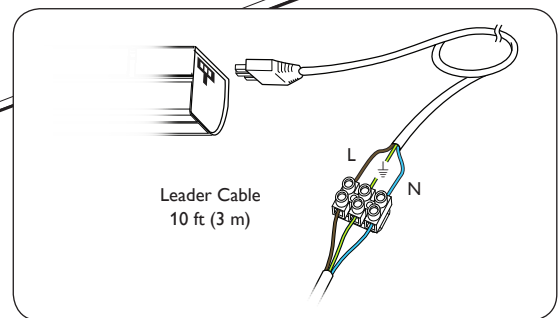

Leader Cable
 10 ft (3 m)

6

Turn the power ON Rétablissez le courant Schalten Sie die Stromzufuhr EIN Encienda la alimentación eléctrica
 Attivare l'alimentazione Schakel de voeding in 電源を ON にします 打开电源

Accessory Item	Color	Size	Item Number	Philips 12NC
eW Profile Powercore Mounting Track	White	25 @ 9 in (229 mm)	120-000064-02	910503700273
		25 @ 19 in (483 mm)	120-000064-00	910503700271
		24 @ 39 in (991 mm)	120-000064-01	910503700272
	Black	25 @ 9 in (229 mm)	120-000064-09	910503700502
		25 @ 19 in (483 mm)	120-000064-10	910503700503
		24 @ 39 in (991 mm)	120-000064-11	910503700504
	Gray	25 @ 9 in (229 mm)	120-000064-06	910503700449
		25 @ 19 in (483 mm)	120-000064-07	910503700450
		24 @ 39 in (991 mm)	120-000064-08	910503700498
eW Profile Powercore Jumper Cable, CE	White	6 in (152 mm)	108-000035-05	910503700265
		12 in (305 mm)	108-000035-06	910503700266
		18 in (457 mm)	108-000035-07	910503700267
		5 ft (1.5 m)	108-000035-08	910503700268
	Black	6 in (152 mm)	108-000035-37	910503700489
		12 in (305 mm)	108-000035-38	910503700490
		18 in (457 mm)	108-000035-39	910503700491
		5 ft (1.5 m)	108-000035-40	910503700492
	Gray	6 in (152 mm)	108-000035-21	910503700473
		12 in (305 mm)	108-000035-22	910503700474
		18 in (457 mm)	108-000035-23	910503700475
		5 ft (1.5 m)	108-000035-24	910503700476
eW Profile Powercore End-to-End Connector, Quantity 5	White	.875 in (22.2 mm)	108-000035-10	910503700368
	Black		108-000035-42	910503700494
	Gray		108-000035-26	910503700478
eW Profile Powercore "Y" Jumper Cable, CE (includes Terminator)	White	16.5 in (419 mm)	108-000035-09	910503700269
	Black		108-000035-41	910503700493
	Gray		108-000035-25	910503700477
eW Profile Powercore Portable Leader Cable, Switched, CE (includes Terminator)	White	10 ft (3 m)	108-000034-01	910503700259
	Black		108-000034-07	910503700461
	Gray		108-000034-04	910503700458

Product Lengths

Fixture

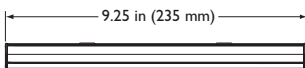

Jumper / Leader Cable

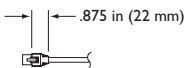

Terminator

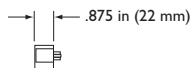

Jumper / Leader Cable

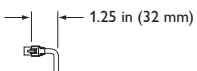

End-to-End Connector

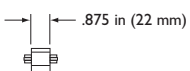

⚠ Do not attempt to install or use a fixture until you read and understand the installation instructions and safety labels.

Assurez-vous d'avoir lu et compris les instructions d'installation et les autocollants de sécurité avant d'installer ou d'utiliser un appareil d'éclairage.

Installieren oder verwenden Sie einen Beleuchtungskörper erst, nachdem Sie die Installationsanweisungen und Sicherheitsetiketten gelesen haben.

No intente instalar o utilizar una lámpara sin previamente haber leído y comprendido las instrucciones de instalación y las etiquetas de seguridad.

Non provare a installare o utilizzare un gruppo di illuminazione se non sono state lette e comprese le istruzioni per l'installazione e le etichette di sicurezza.

Probeer geen armaturen aan te brengen of te gebruiken voordat u de plaatsingsinstructies en veiligheidslabels hebt gelezen en begriipt.

置手順と安全ラベルを読み理解してから、フィクスチャの設置または使用を始めてください。

阅读并理解安装说明和安全标签之前，切勿试图安装或使用灯具

⚠ Do not use a fixture if the lens, housing, or power cables are damaged.

N'utilisez pas un appareil d'éclairage si la lentille, le boîtier ou les câbles d'alimentation sont endommagés.

Verwenden Sie den Beleuchtungskörper nicht, wenn das Lampenglas, Gehäuse oder ein Netzkabel beschädigt ist.

No utilice una lámpara que presente daños en el cristal o plástico, estructura o en los cables de alimentación eléctrica.

Non utilizzare un gruppo di illuminazione se il gruppo ottico, l'alloggiamento o i cavi di alimentazione sono danneggiati.

Gebruik een armatuur niet indien de lens, behuizing of voedingkabels zijn beschadigd.

レンズ、ハウジング、または電源ケーブルが損傷している場合は、フィクスチャを使用しないでください。

如果灯镜片、灯壳或电线受损，切勿使用产品。

⚠ Fixtures have line voltage risk of shock and no user serviceable parts. Do not attempt to open them.

La tension composée des appareils d'éclairage présente un risque de choc électrique et les pièces ne sont pas réparables par l'utilisateur. Ne tentez pas de les ouvrir.

Die elektrischen Leiter der Beleuchtungskörper können einen Stromschlag verursachen, und die Beleuchtungskörper enthalten keine vom Benutzer wartbaren Teile. Versuchen Sie nicht, einen Beleuchtungskörper zu öffnen.

Al manipular las lámparas existe riesgo de descarga eléctrica. Las lámparas no contienen piezas que puedan ser reparadas por el usuario. No intente abrirlas.

I gruppi di illuminazione presentano rischi di scosse elettriche e non contengono componenti sostituibili dall'utente. Non aprirli.

Bij armaturen is een risico op schokken door lijnspanning aanwezig en armaturen bevatten geen onderdelen die door de gebruiker kunnen worden onderhouden. Probeer armaturen niet open te maken.

フィクスチャには、感電の危険がある電流が流れており、ユーザーが保守できる部品はありません。フィクスチャを開けようとししないでください。

灯具存在线电压电击的危险，且无用户可修理的部件。切勿试图打开产品。

⚠ Use reverse-phase (trailing-edge) ELV-type dimmers only.

Refer to dimmer manufacturer for information on the compatibility of specific dimmer / fixture combinations. Test all dimmer / fixture combinations prior to permanent installation. Refer to www.colorkinetics.com/support/appnotes/ for further information and warnings.

⚠ Do not use a fixture for any voltage for which it is not rated. Do not exceed the specified voltage and current input for any fixture.

N'utilisez pas un appareil d'éclairage sous une tension autre que la tension nominale. Ne dépassez jamais la tension et la consommation de courant spécifiées pour un appareil d'éclairage.

Verwenden Sie den Beleuchtungskörper nicht bei Stromspannungen, für die der Beleuchtungskörper nicht bestimmt ist. Die für einen Beleuchtungskörper angegebene Spannung und der angegebene Eingangsstrom dürfen nicht überschritten werden.

No conecte la lámpara a un voltaje distinto al especificado. No sobrepase el voltaje o la corriente eléctrica especificados en ninguna de las lámparas.

Non utilizzare un gruppo di illuminazione su una rete elettrica non classificata. Non superare la tensione e la corrente di ingresso specificate per il gruppo di illuminazione.

Gebruik een armatuur niet bij een spanning waarvoor deze niet is bestemd. De opgegeven spannings- en stroomwaarden mogen voor een armatuur niet worden overschreden.

規定以外の電圧でフィクスチャを使用しないでください。フィクスチャに供給される電圧および電流が、指定された値を超えないようにしてください。

切勿在任何非额定电压的情况下，使用产品。切勿超出灯具规定的电压与输入电流。

⚠ Ensure that main power supply is off before installing or wiring a fixture.

Assurez-vous que l'alimentation principale est coupée avant d'installer ou de câbler un appareil d'éclairage.

Vergewissern Sie sich, dass die Stromzufuhr unterbrochen ist, bevor Sie einen Beleuchtungskörper installieren oder ans Stromnetz anschließen.

Antes de instalar o cablear una lámpara, asegúrese de que la alimentación eléctrica esté desconectada.

Accertarsi che la tensione di rete principale sia disattivata prima di installare o cablare un gruppo di illuminazione.

Zorg dat de stroomvoorziening is uitgeschakeld voordat u een armatuur installeert of bedrading aanbrengt.

フィクスチャを設置または配線する前に、主電源がオフであることを確認してください。

对灯具进行安装或接线时，需确保主电源已关闭。

⚠ The U.S. National Electrical Code (NEC) does not permit cords to be concealed where damage to insulation may go unnoticed. To prevent fire danger, do not run cord behind walls, ceilings, soffits or cabinets where it may be inaccessible for examination. Cords should be visually examined periodically and immediately replaced when damage is noted.

⚠ Not intended for recessed installation in ceilings or soffits. Not intended for surface installation inside built-in residential furnishings.

⚠ To prevent the risk of fire do not install closer than .25 inches (7 mm) to cabinet wall or in a compartment smaller than 12 inches by 12 inches wide and high by 12, 24 or 44 inches long for the 9.25, 19.25 and 39.25 inch fixtures, respectively.

⚠ To reduce the risk of fire, electric shock or injury to persons: use only insulated staples or plastic ties to secure cords; route and secure cords so that they will not be pinched or damaged when the cabinet is pushed to the wall.

⚠ Do not hot swap fixtures. Ensure that power to the series is off before connecting or disconnecting individual fixtures.

Ne remplacez pas les appareils d'éclairage à chaud. Assurez-vous que l'alimentation série est coupée avant de brancher ou de débrancher chaque appareil d'éclairage.

Tauschen Sie einen Beleuchtungskörper nicht im eingeschalteten Zustand aus. Vergewissern Sie sich, dass die Stromzufuhr zu einer Serie von Beleuchtungskörpern unterbrochen ist, bevor Sie einzelne Beleuchtungskörper anschließen oder vom Stromnetz trennen.

No sustituya lámparas mientras estén calientes. Asegúrese de que la alimentación eléctrica de toda la serie de lámparas esté desconectada antes de conectar o desconectar una lámpara individual.

Non sostituire a caldo i gruppi di illuminazione. Accertarsi che l'alimentazione in serie sia disattivata prima di collegare o scollegare i singoli gruppi di illuminazione.

Vervang een armatuur niet terwijl deze aan is. Zorg dat de voeding naar de reeks is uitgeschakeld voordat u afzonderlijke armaturen aansluit of loskoppelt.

電源を入れたままフィクスチャを交換しないでください。個々のフィクスチャを接続または取り外す前に、直列フィクスチャへの電源がオフであることを確認してください。

切勿热插拔产品。连接或断开单个灯具之前，必须确保供该系列之电源已关闭。

⚠ This device complies with Part 15 of the FCC Rules. Operation is subject to the following two conditions: (1) this device may not cause harmful interference, and (2) this device must accept any interference received, including interference that may cause undesired operation.

These limits are designed to provide reasonable protection against harmful interference in a residential installation. This equipment generates, uses and can radiate radio frequency energy and, if not installed and used in accordance with the instructions, may cause harmful interference to radio communications. However, there is no guarantee that interference will not occur in a particular installation. If this equipment does cause harmful interference to radio or television reception, which can be determined by turning the equipment off and on, the user is encouraged to try to correct the interference by one or more of the following measures:

- Reorient or relocate the receiving antenna.
- Increase the separation between the equipment and receiver.
- Connect the equipment into an outlet on a circuit different from that to which the receiver is connected.
- Consult the dealer

⚠ This Class B digital apparatus complies with Canadian ICES-003. Cet appareil numérique de la classe B est conforme à la norme NMB-003 du Canada.



Philips Color Kinetics
3 Burlington Woods Drive
Burlington, Massachusetts 01803 USA
Tel 888.385.5742
Tel 617.423.9999
Fax 617.423.9998
www.philipscolorkinetics.com

Copyright © 2008 – 2011 Philips Solid-State Lighting Solutions, Inc. All rights reserved.
Chromacore, Chromasic, CK, the CK logo, Color Kinetics, the Color Kinetics logo, ColorBlast, ColorBlaze, ColorBurst, ColorGraze, ColorPlay, ColorReach, iW Reach, eW Reach, DIMand, EssentialWhite, eW, iColor, iColor Cove, IntelliWhite, iW, iPlayer, Optibin, and Powercore are either registered trademarks or trademarks of Philips Solid-State Lighting Solutions, Inc. in the United States and / or other countries. All other brand or product names are trademarks or registered trademarks of their respective owners. Due to continuous improvements and innovations, specifications may change without notice.